

Rev.	Amendments	Date	Made By	Chk'd By

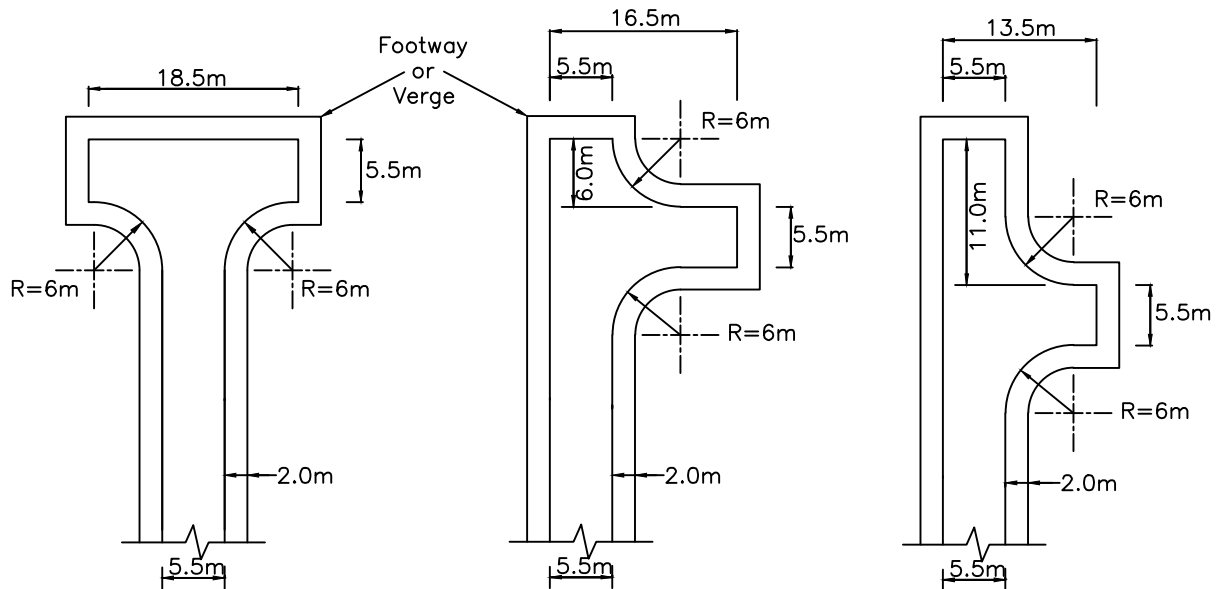
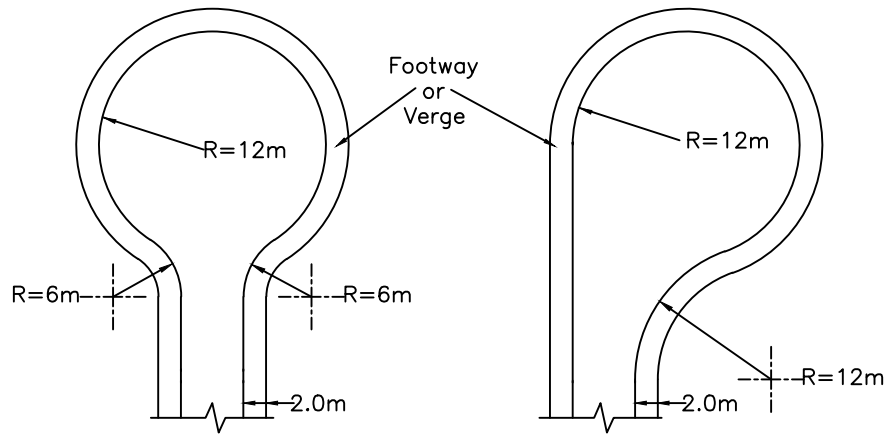

**NOTES**

1. Where no footway or verge adjoins the turning head a 1m margin must be provided to allow for the overhang of turning vehicles.
2. Variations may be proposed as long as a swept path analysis is provided to ensure service and delivery vehicles can turn
3. Drives and accesses must be carefully planned to discourage parking in the turning area reducing its availability.

**TURNING AREAS – RESIDENTIAL STREETS**

**HIGHWAY DESIGN GUIDE STANDARD DETAILS**

**RHONDDA CYNON TAF  
COUNTY BOROUGH COUNCIL**



Drawn	DA
Checked	SZ
Date	Apr '11
Scale	NTS
Drg. No.	100
Rev.	