

Rev.	Amendments	Date	Made By	Chk'd By

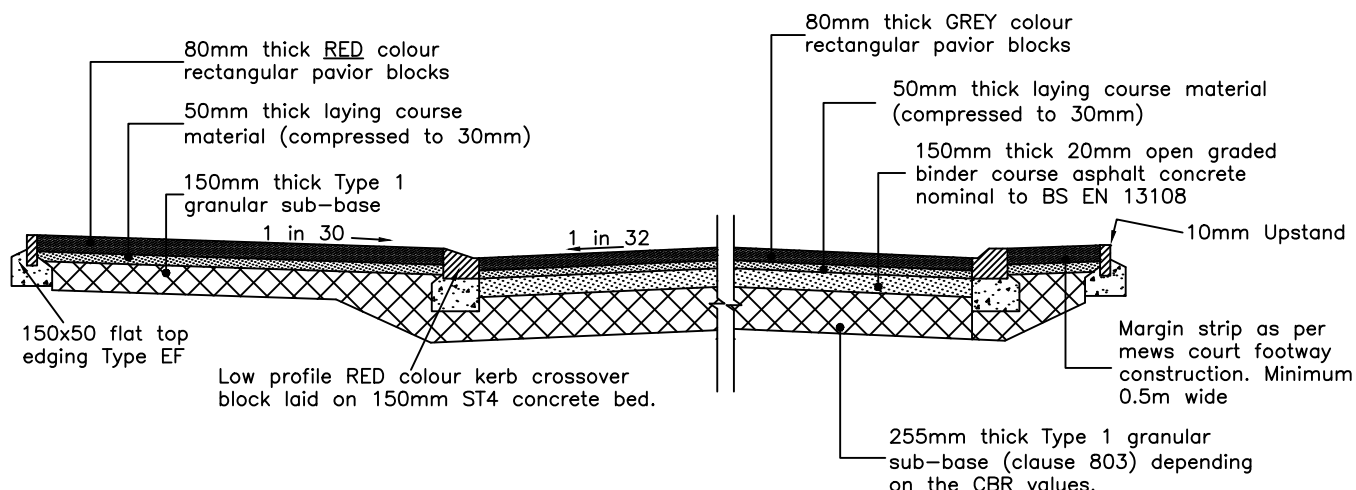

VEHICULAR CROSSOVER AND CARRIAGEWAY CONSTRUCTION

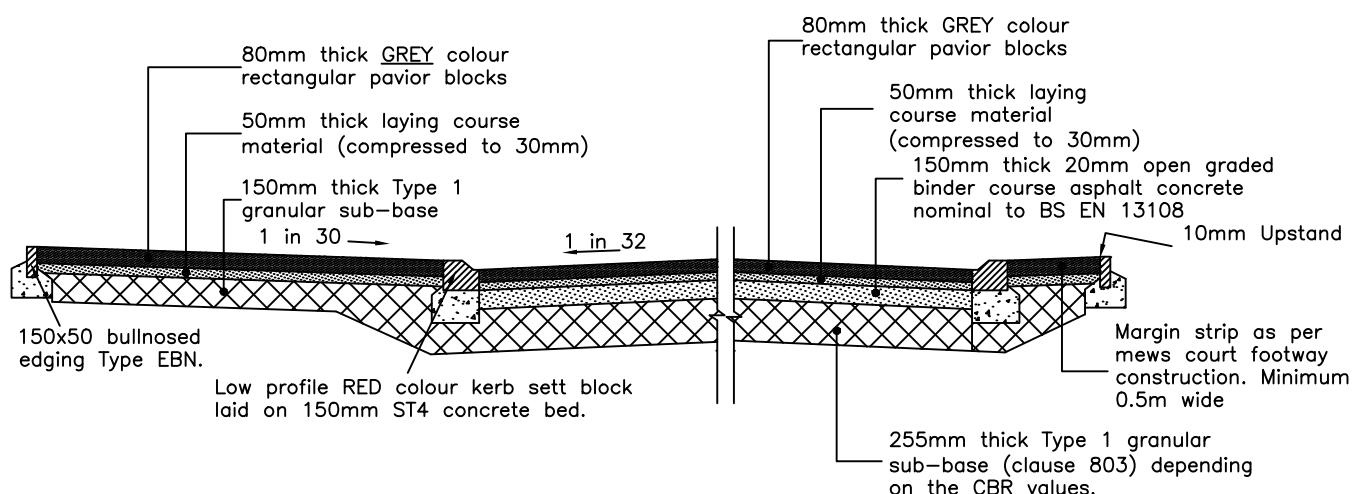

FOOTWAY AND CARRIAGEWAY CONSTRUCTION

NOTES

1. Minimum carriageway construction thickness to be 450mm.
2. All dimensions are in millimetres unless otherwise stated
3. Fine dry sand to BS 7533-3 (Annex D) to be vibrated into joints until joints are full.
4. Laying course material to BS 7533-3 (Annex D)

MEWS COURT – CARRIAGEWAY, FOOTWAY AND
VEHICULAR CROSSOVER CONSTRUCTION

HIGHWAY DESIGN GUIDE STANDARD DETAILS

**RHONDDA CYNON TAF
COUNTY BOROUGH COUNCIL**



Drawn	DA
Checked	SZ
Date	Apr '11
Scale	NTS
Drg. No.	120
Rev.	