

Rev.	Amendments	Date	Made By	Chk'd By

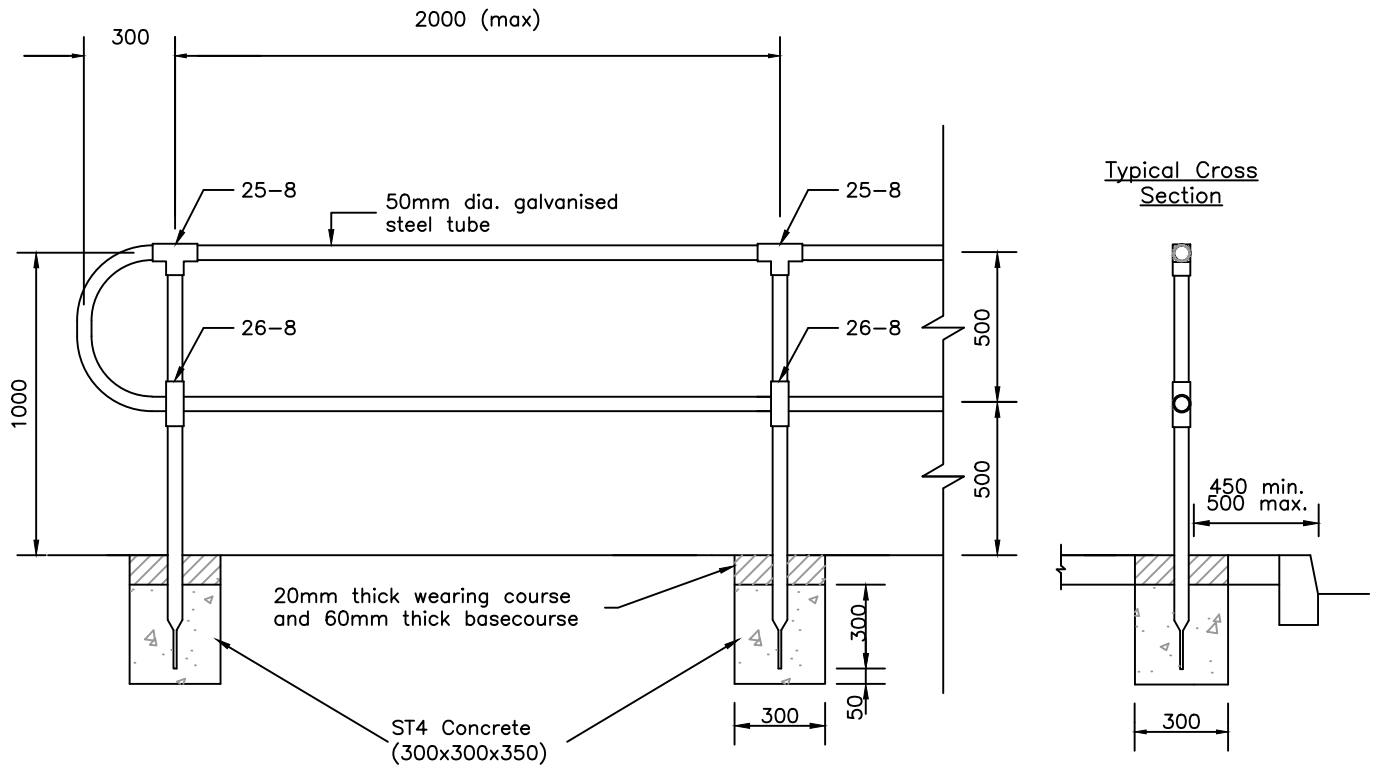

**NOTES**

1. Kee Klamp ref. 8 is suitable for galvanised steel tubing 48.3 outside diameter and 40 inside diameter to BS 1387.
2. Galvanising is to be in accordance with BS EN ISO 1461.
3. All connector references are of Kee Klamp origin.
4. A similar approved alternative may be used with the agreement of the Engineer.
5. All dimensions are in millimetres unless otherwise stated.

**PEDESTRIAN GUARDRAIL (KEE KLAMP)**

**HIGHWAY DESIGN GUIDE STANDARD DETAILS**

**RHONDDA CYNON TAF  
COUNTY BOROUGH COUNCIL**



Drawn	DA
Checked	SZ
Date	Apr '11
Scale	NTS
Drg. No.	162
Rev.	