

Rev.	Amendments	Date	Made By	Chk'd By

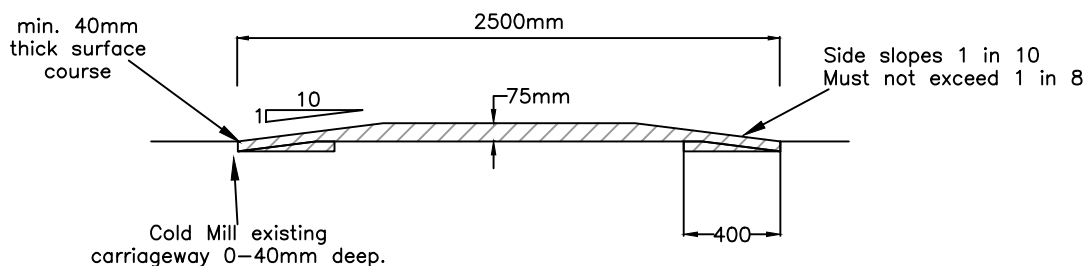

SECTION A-A

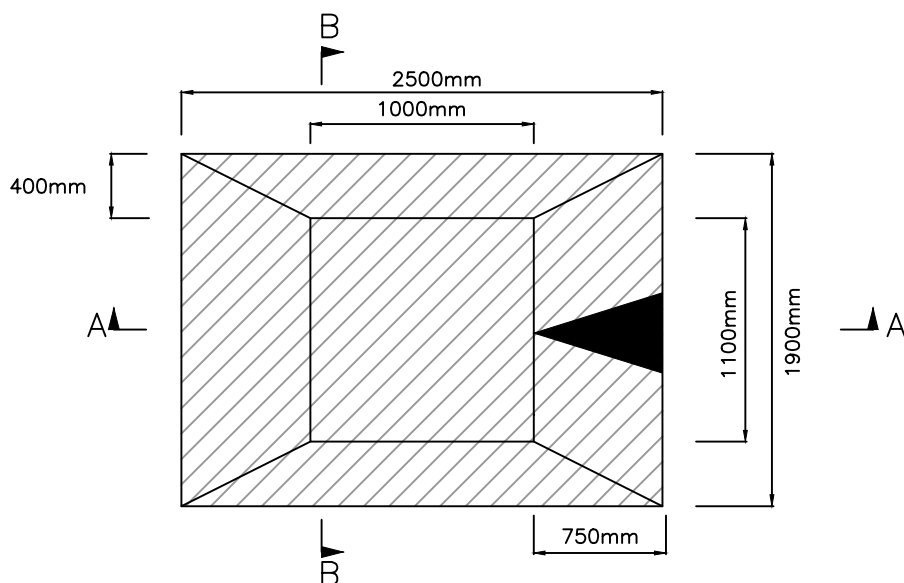
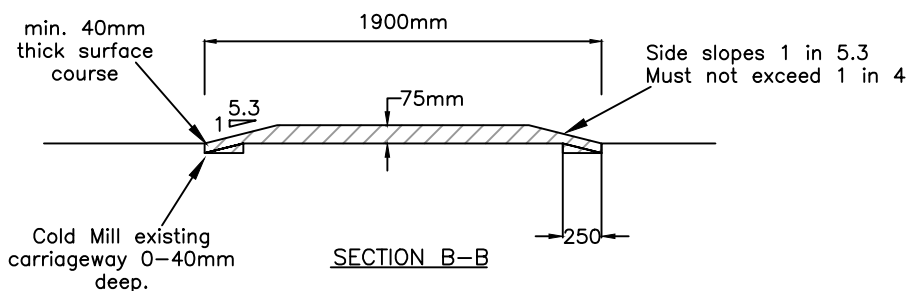

SECTION B-B

**NOTES**

1. The existing carriageway surface must be sprayed with tack coat (Class C40B4) cationic emulsion to BS EN 13808 at a rate of 0.5 litres/m<sup>2</sup>.
2. The vertical face of the saw cut joint shall be treated with either, hot bituminous binder with penetration no less than 40/60 pen, or hot elastomeric polymer modified bituminous binder complying with BS EN 14023 with penetration no less than 40 pen.
3. Do not scale, use dimensioned figures only.
4. Road markings to be in accordance with current Traffic Signs Regulations and General Directions
5. Construction Tolerances will be :- Height and Levels ±10mm  
Plan Dimensions ±50mm

**SPEED CUSHION (CONSTRUCTION)**

**HIGHWAY DESIGN GUIDE STANDARD DETAILS**

**RHONDDA CYNON TAF  
COUNTY BOROUGH COUNCIL**



Drawn	DA
Checked	SZ
Date	Apr '11
Scale	NTS
Drg. No.	183
Rev.	