

Rev.	Amendments	Date	Made By	Chk'd By

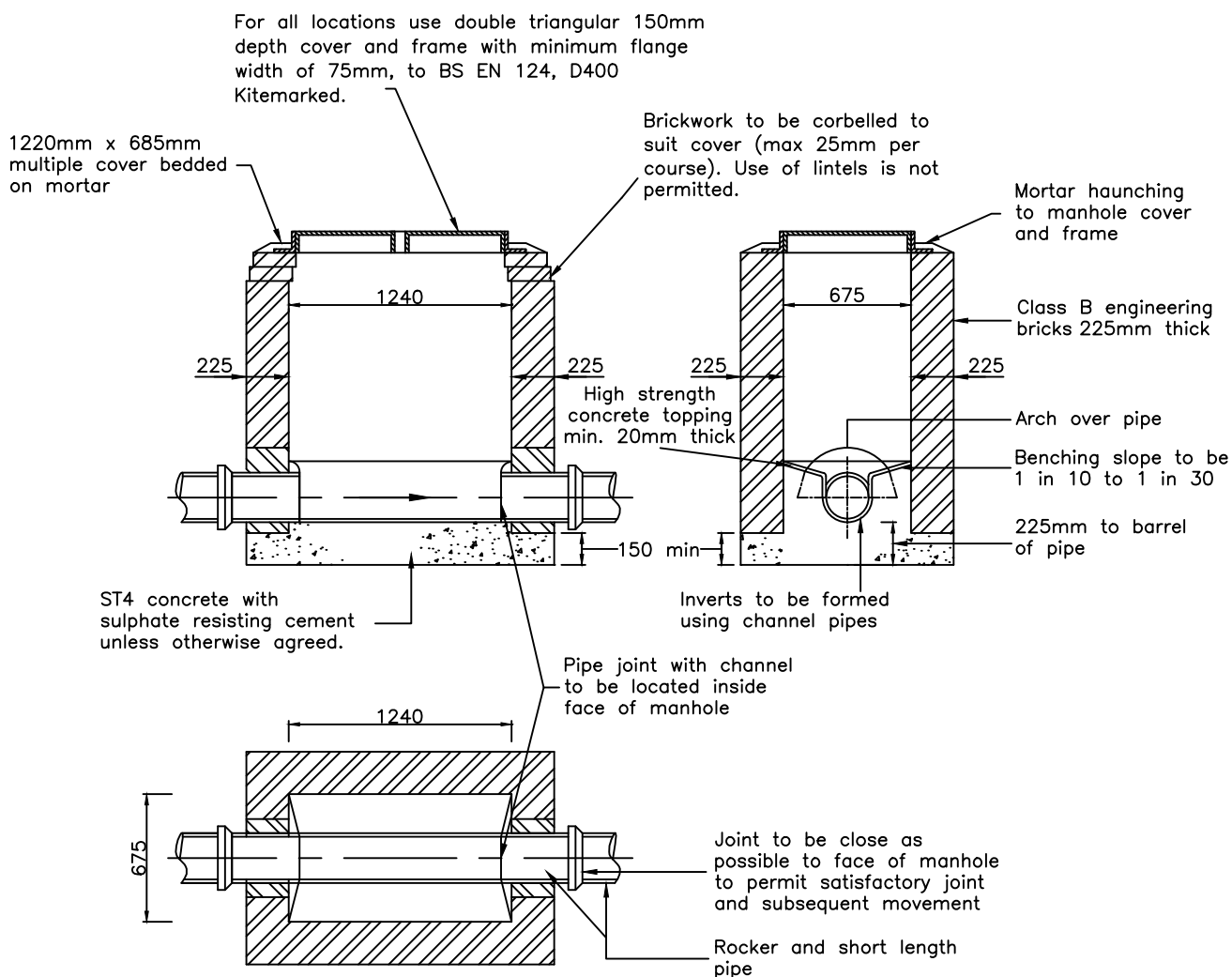

NOTES

1. All dimensions are in millimetres unless otherwise stated.
2. Brickwork manholes should be a last case scenario and where the chamber height is less than 900mm and a Type B manhole can not be used, a Type F manhole will be considered as an alternative.
3. For Type C manholes, the internal dimensions are normally 1240 x 675, but manhole width should be increased for pipes larger than 225 diameter to give 225 benching each side with the brickwork corbelled down to suit cover.

MANHOLE DETAIL – TYPE C

Depth From Ground Level to Soffit of Pipe 1m to 1.25m

HIGHWAY DESIGN GUIDE STANDARD DETAILS

RHONDDA CYNON TAF
COUNTY BOROUGH COUNCIL



Drawn	DA
Checked	SZ
Date	Apr '11
Scale	NTS
Drg. No.	202
Rev.	