

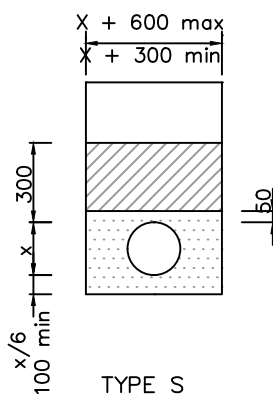

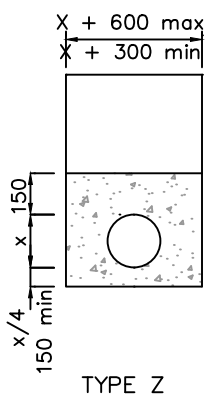

Rev.	Amendments	Date	Made By	Chk'd By



KEY

-  Granular material to Specification for Highway Works Clause 503.3 (i).
-  ST4 Concrete.
-  Class 8 material to Specification for Highway Works Clause 503.3 (iv).

NOTES

Flexible joint in concrete

1. Flexible joints must be provided in the concrete by inserting compressible board (fibreboard or polystyrene) at centres of 6m maximum and at all pipe joints.
2. A board thickness of 18mm for pipes up to 450mm nominal diameter and 36mm for pipes over 450mm in diameter.

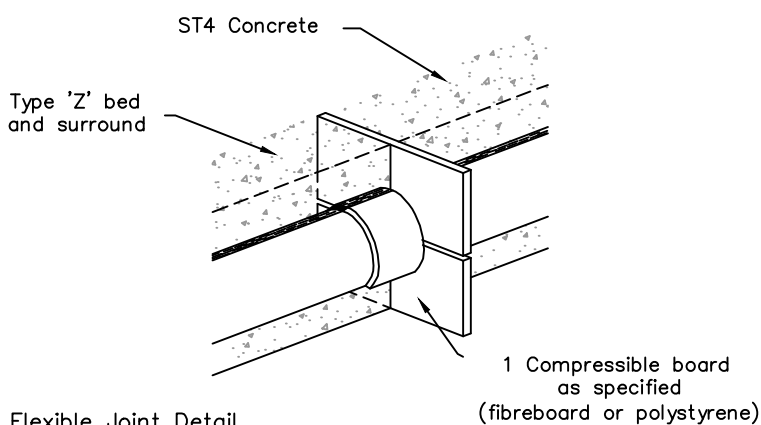

NOTES

1. All dimensions are in millimetres unless otherwise stated.
2. Dimension X is the external diameter of the pipe.
3. The minimum or maximum width of the trench applies on and below a line 300mm above the outside top of the pipe. Above the 300mm line the trench backfill material shall be as described the spec for highway works.
4. The concrete bed or surround may extend to the sides of the trench or be of minimum width. Class 8 material is to be used to fill any voids so for

TRENCH, BEDDING AND FLEXIBLE JOINT

HIGHWAY DESIGN GUIDE STANDARD DETAILS

RHONDDA CYNON TAF
COUNTY BOROUGH COUNCIL



Drawn	DA
Checked	SZ
Date	Apr '11
Scale	NTS
Drg. No.	211
Rev.	