

Rev.	Amendments	Date	Made By	Chk'd By

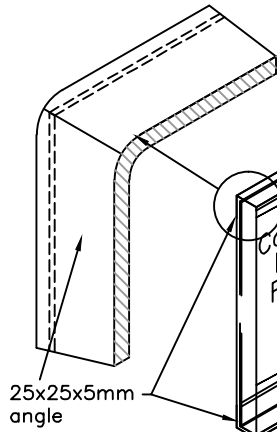

Back board material to be aluminium or hard plastic

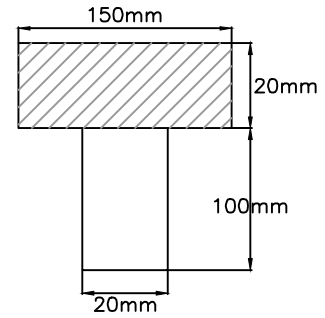

Council Logo Refer to Detail

STREET NAME

Length to suit Street Name Council Logo and "No Through Road" motif.

40x40mm

Finished footway /ground level

Surface Course

Binder Course

ST5 Concrete

700mm

80mm

350mm

300mm

ST5 Concrete

150mm thick sub-base Type 1

NOTES

1. "No through road" symbol to be shown if required. Refer to Drg. No. 816.1 TSRGD.
2. Rhondda Cynon Taff County Borough Council crest to be used on the sign plate.
3. All steel to be Grade 43 and galvanised to BS EN ISO 1461.
4. All dimensions are in millimetres unless otherwise stated.
5. Height of Street Name letters to be 90mm.
6. Sign to be located within footway in front of back edgings

STREET NAME PLATE

HIGHWAY DESIGN GUIDE STANDARD DETAILS

RHONDDA CYNON TAF
COUNTY BOROUGH COUNCIL



Drawn	DA
Checked	SZ
Date	Apr '11
Scale	NTS
Drg. No.	252
Rev.	