

Rev.	Amendments	Date	Made By	Chk'd By

Note Cover to reinforcement= 50mm

t – thickness of wall based on a 102.5mm brick thickness

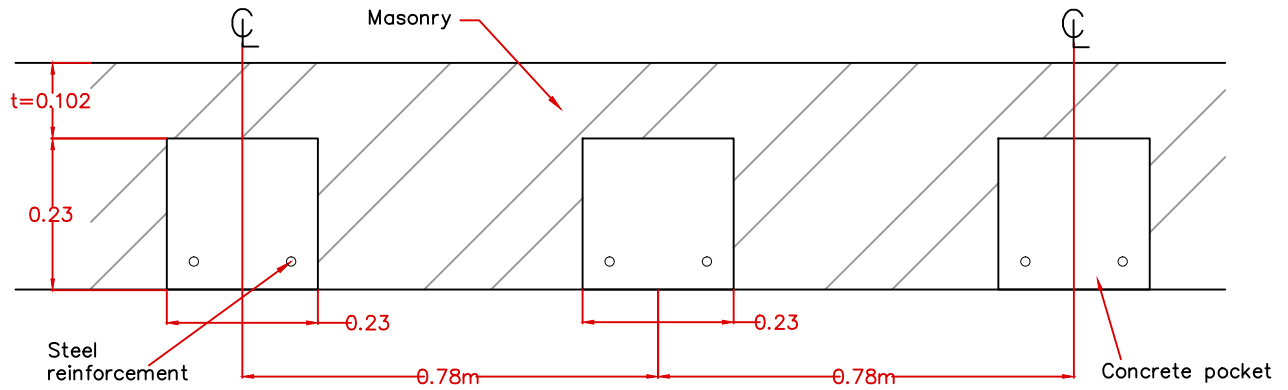

Wall designed to EC7.

Assumptions made for this design :

- Angle of friction on base = 35 degrees
- No fence or parapet is fixed to the wall
- Water table is below formation level
- Bearing capacity of the ground below the foundation is 150kN/m<sup>2</sup>.

The ground below the foundation should be checked that the angle of friction is at least 35 degrees and the bearing capacity is at least 150kN/m<sup>2</sup>.

The dimensions shown in the table are only applicable to walls at locations that meet the above criteria. If these criteria are not met then the walls should be designed to suit the prevailing factors.

All pocket type reinforced masonry retaining walls must also include:

- A back of wall drainage system;
- Weepholes;
- Joints at appropriate spacings;
- Finishes to highway standards.
- The reinforced concrete foundation slab must be laid on a blinding layer 75mm thick.
- Buried reinforced concrete must be waterproofed with two coats of bitumen.

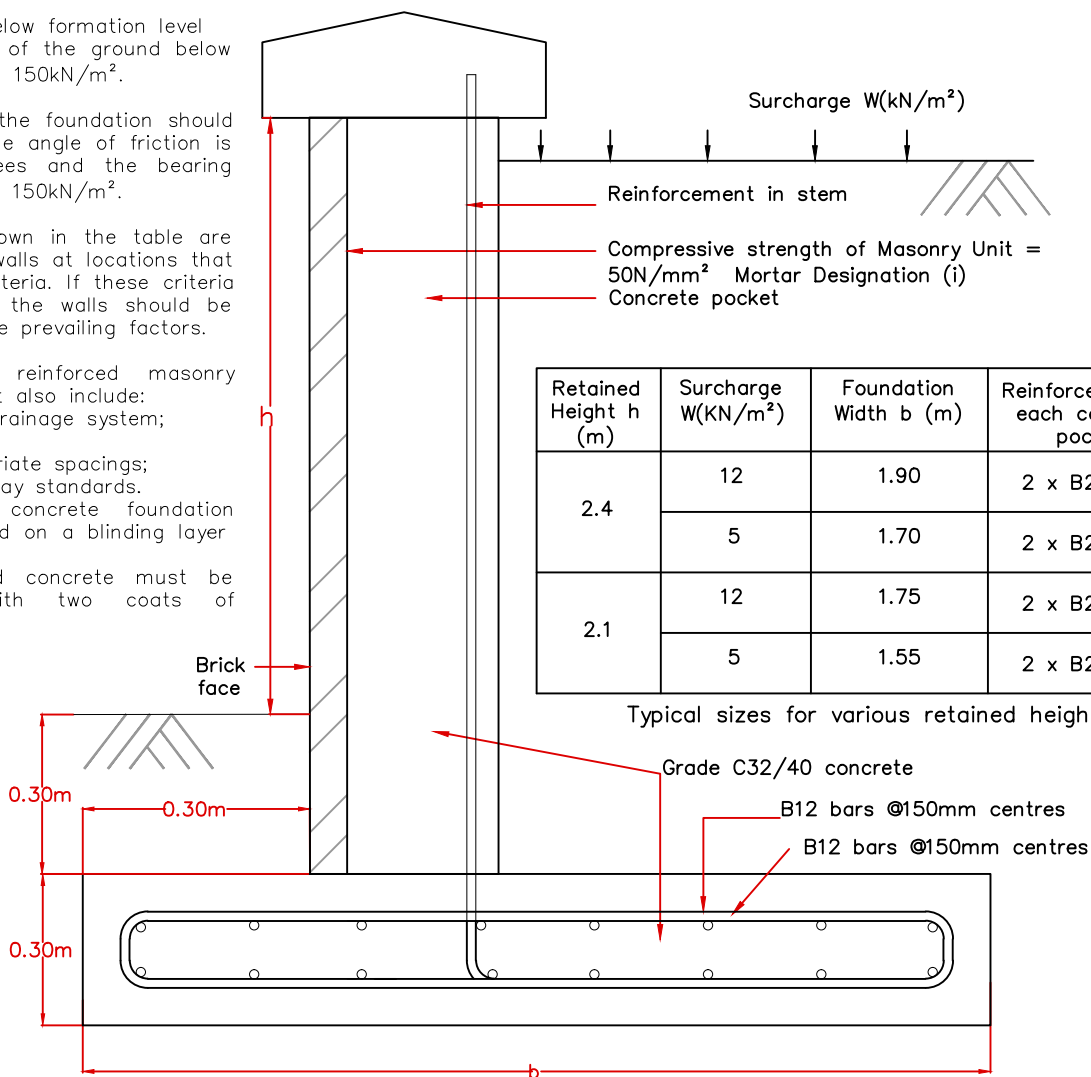

## POCKET TYPE REINFORCED MASONRY WALL

HIGHWAY DESIGN GUIDE STANDARD DETAILS

RHONDDA CYNON TAF  
COUNTY BOROUGH COUNCIL



Drawn	AM
Checked	MR
Date	Apr '11
Scale	NTS
Drg. No.	294
Rev.	