

Rev.	Amendments	Date	Made By	Chk'd By

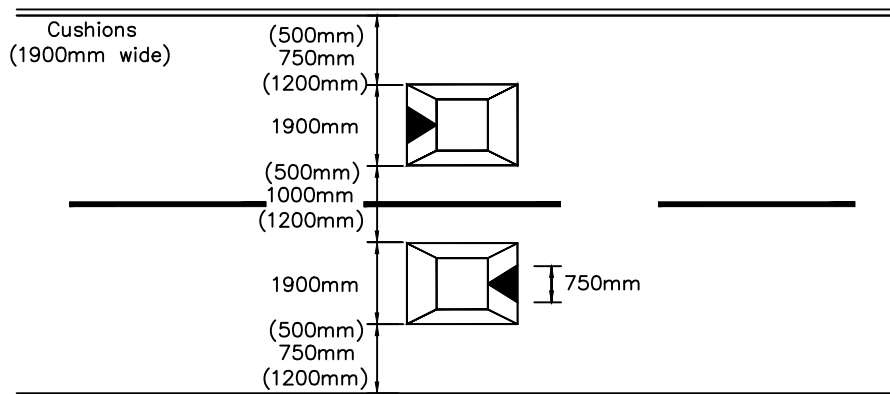

TWO SPEED CUSHION LAYOUT
ROAD WIDTHS BETWEEN 5300mm and 7400mm

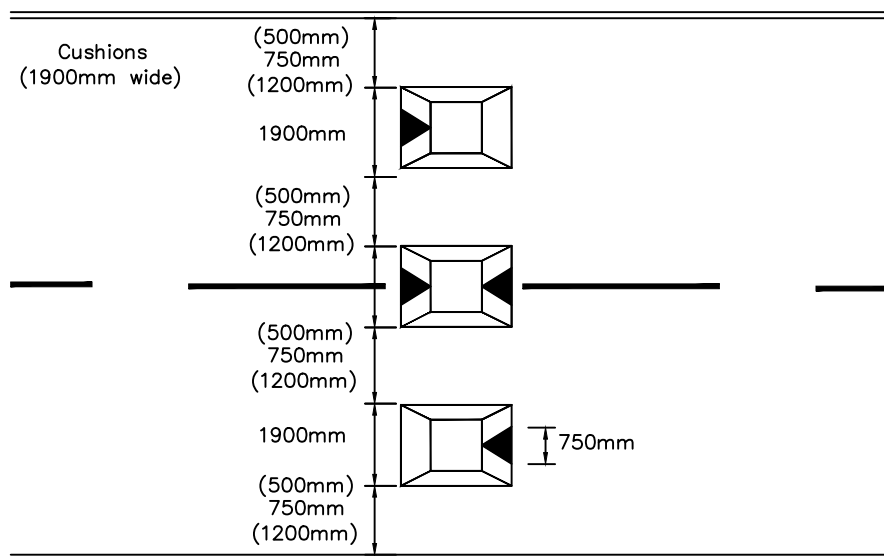

THREE SPEED CUSHION LAYOUT
ROAD WIDTHS BETWEEN 7700mm AND 10,500mm

NOTES

1. The existing carriageway surface must be sprayed with tack coat (Class C40B4) cationic emulsion to BS EN 13808 at a rate of 0.5 litres/m².
2. The vertical face of the saw cut joint shall be treated with either, hot bituminous binder with penetration no less than 40/60 pen, or hot elastomeric polymer modified bituminous binder complying with BS EN 14023 with penetration no less than 40 pen.
3. Do not scale, use dimensioned figures only.
4. Road markings to be in accordance with current Traffic Signs Regulations and General Directions

SPEED CUSHIONS AND ROAD MARKINGS

HIGHWAY DESIGN GUIDE STANDARD DETAILS

**RHONDDA CYNON TAF
COUNTY BOROUGH COUNCIL**



Drawn	DA
Checked	SZ
Date	Apr '11
Scale	NTS
Drg. No.	182
Rev.	