

Rev.	Amendments	Date	Made By	Chk'd By

MANHOLE DETAIL – TYPE E
DEPTH FROM GROUND LEVEL TO SOFFIT OF PIPE 1.0m TO 1.45m

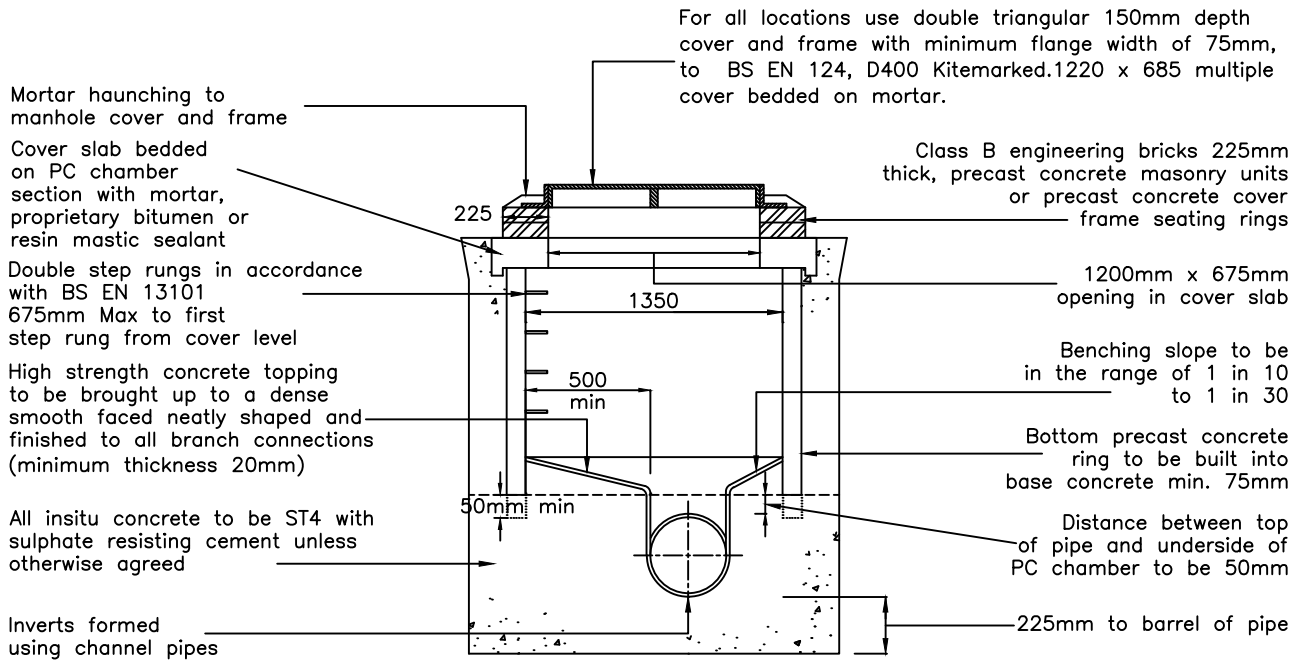

MANHOLE DETAIL – TYPE F
DEPTH FROM GROUND LEVEL TO SOFFIT OF PIPE LESS THAN 1.0m

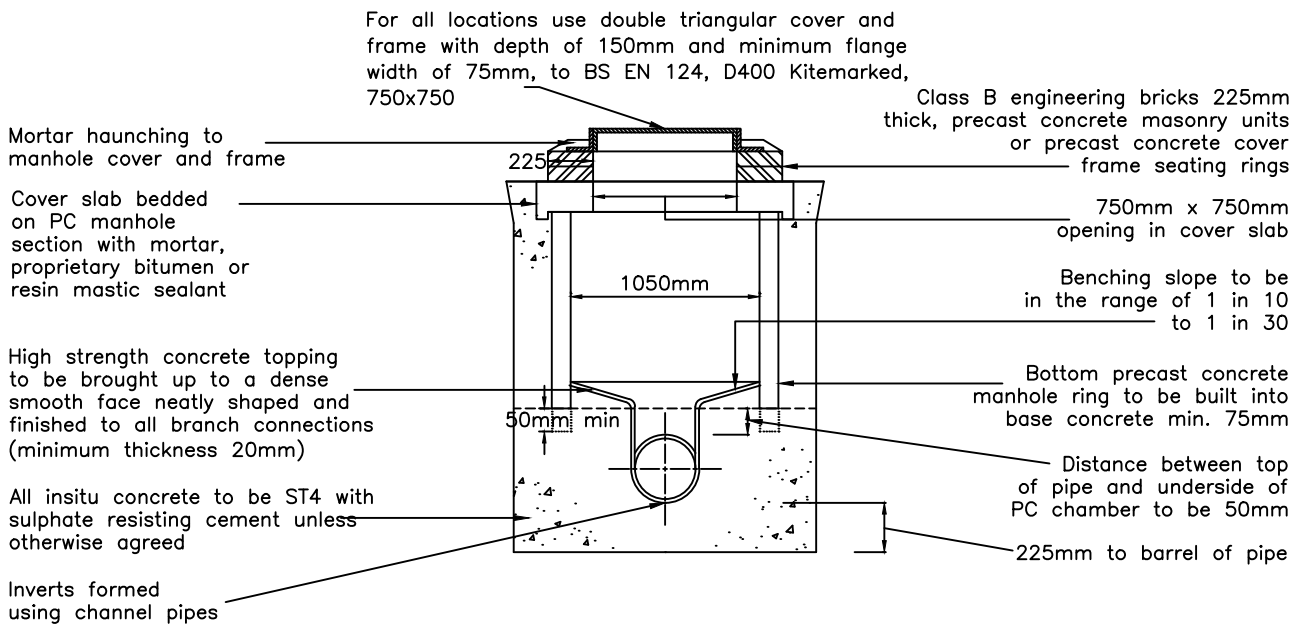

- NOTES**
- All dimensions are in millimetres unless otherwise stated

MANHOLE DETAIL – TYPES E & F

HIGHWAY DESIGN GUIDE STANDARD DETAILS

RHONDDA CYNON TAF
COUNTY BOROUGH COUNCIL



Drawn	DA
Checked	SZ
Date	Apr '11
Scale	NTS
Drg. No.	204
Rev.	