

Existing Gateway signage to be taken down. Red surface treatment to be refreshed/relaid with 20 / 20 MPH roundels

Existing Gateway signage to be taken down. Red surface treatment to be refreshed/relaid with 20 / 20 MPH roundels

Existing Gateway signage to be taken down. Red surface treatment to be refreshed/relaid with 20 / 20 MPH roundels

6M flat top speed hump (Refer to Detail A)

Existing Gateway signage to be taken down. Red surface treatment to be refreshed/relaid with 20 / 20 MPH roundels

New Gateway Signage

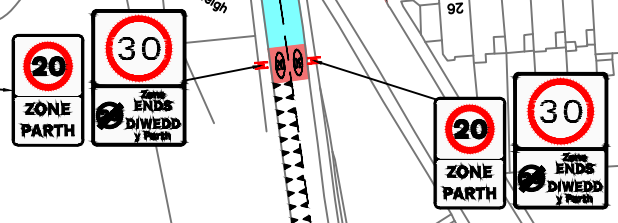

DETAIL A - STANDARD 6 METRE FLAT TOP HUMPS AND ROAD MARKINGS.

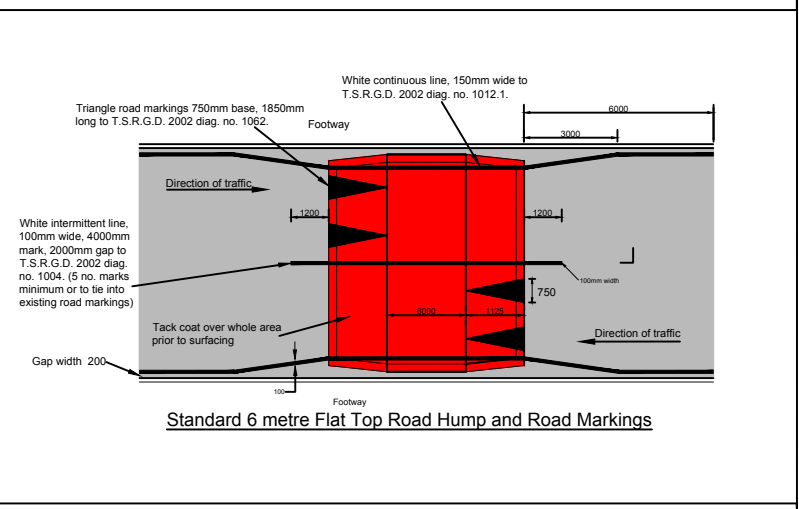

DETAIL B - SPEED CUSHION DETAIL - 2 OR 3 CUSHIONS POSITIONED AT THE LOCATIONS SHOWN - NUMBER OF CUSHIONS IS GOVERNED BY ROAD WIDTH

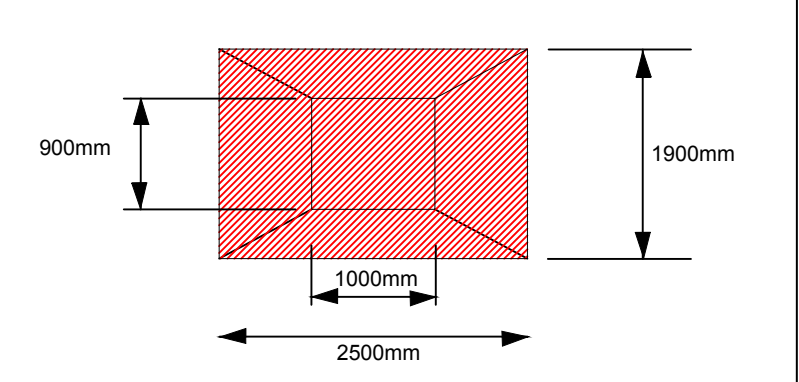

Key

	Proposed 20 MPH Speed Limit
	Speed Cushion (See Detail B)
	6M Flat Top Speed Hump (See Detail A)
	20mph / 30mph road markings

Note: Any existing road markings are to be reinstated following the works.

CILHAUL TERRACE - MISKEN  
20 MPH ZONE AND TRAFFIC CALMING

Group Director Environmental Services, Rhondda Cynon Taf County Borough Council, Sardis House, Sardis Road, Pontypridd, CF37 1DU.		Cyfarwyddwr Cyfadrn y Gwasanaethau Amgylchedd, Cyngor Bwrdeistref Sirof Rhondda Cynon Taf, Ty Sardis, Sardis Road, Pontypridd, CF37 1DU.		Size Maint A3	
File No. Rhif y ffeil		Scale Graddfeydd	1:1250	Drg. No. Rhif y cynllun	G-0-4
Rev No.	Amendment Details			Date	Made/Check/ App
A	Speed Hump outside Hillcrest moved south in between the two accesses so that their access is not obstructed Dragon Teeth Road Markings Following R242 Report			10/07 24/10	DK DK AP TP

Reproduced from the Ordnance Survey mapping with the permission of the Controller of Her Majesty's Stationery Office. © Crown copyright. Unauthorised reproduction infringes Crown copyright and may lead to prosecution or civil proceedings. Rhondda Cynon Taff County Borough Council Licence No 100023458. 2010